



MODEL

WESTCOTT 2000

INSTALLATION SPECIFICATION SHEET

These instructions must be used in conjunction with the 'General Installation Instructions' for Masport wood fires.

CLEARANCE REQUIREMENTS

This fire has been tested and complies to the Australian/New Zealand Standard AS/NZS 2918:2001 and all installations must be in accordance with the minimum clearances to combustibles indicated in these instructions.

The minimum clearances to combustables may be reduced if the combustable walls are shielded with an approved non-combustable material. Details of suitable materials and appropriate clearance reduction factors are present in Section 3 of AS/NZS 2918:2001.

POSITIONING YOUR FREE-STANDING WOODFIRE

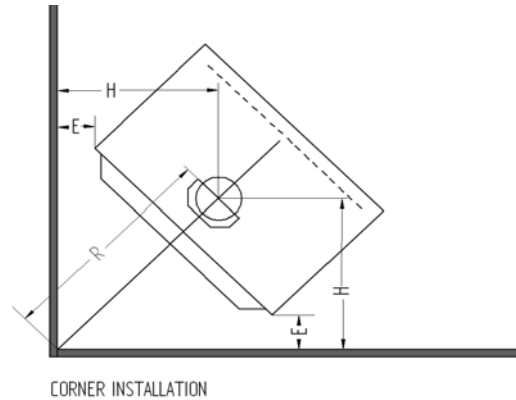
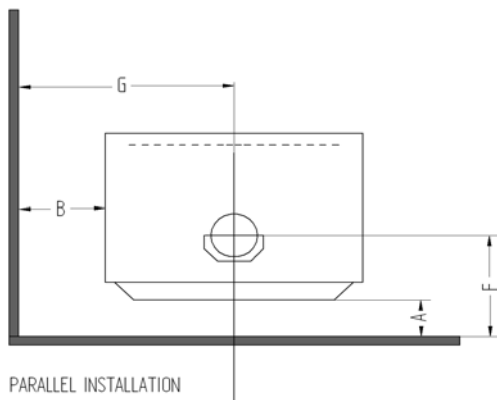

NEW ZEALAND

MINIMUM DISTANCES TO HEAT SENSITIVE WALLS (mm)

MODEL	FLUE HEAT SHIELD	A	B	E	F	G	H	R§
NOT AVAILABLE								

AUSTRALIA

MINIMUM DISTANCES TO HEAT SENSITIVE WALLS (mm)

MODEL	FLUE HEAT SHIELD	A	B	E	F	G	H	R§
WESTCOTT 2000	HAWKWIND STD FLUE KIT	250	200	150	370	470	426	602
	AIR-GROUP SPECIAL INSULATED FLUE KIT*	100	225	50	220	495	326	461

§ Valid only when the room walls are at 90° to each other.

‡ Note: Clearances are for fire hazard only. For durability of finishes or surfaces you should contact the relevant manufacturer for their specification. Masport accepts no responsibility for the deterioration of surfaces or finishes.

See " INSTALLING THE FLUE " for recommended Australian flue systems.

PRT. NO. 592004

DATE: 26.03.2012

FLOOR PROTECTOR (Hearth) REQUIREMENTS PARALLEL INSTALLATION

MINIMUM FLOOR PROTECTOR DIMENSIONS IN mm

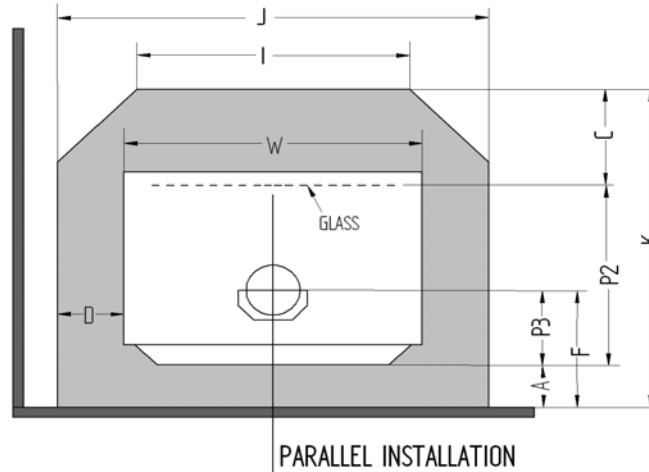

DIMENSIONS IN THE TABLE ARE VALID ONLY WHEN THE FIRE IS EXACTLEY AT ITS MINIMUM ALLOWABLE WALL CLEARANCE.

NEW ZEALAND

MODEL	Flue Shield	Floor Protector height	A#	C#	D	F	I	J	K#	P2	P3	W	Floor Protector Type Ø
NOT AVAILABLE													

AUSTRALIA - ALL WITH FLUE HEATSHIELD

MODEL	Flue Shield	Floor Protector height	A#	C#	D	F	I	J	K#	P2	P3	W	Floor Protector Type Ø
WESTCOTT 2000	HSF		250	300	100	370	440	740	840	290	120	540	ASH
	AGA		100	300	100	220	440	740	690	290	120	540	ASH1

HSF: HAWKWIND STD FLUE KIT

AGA: AIR GROUP / AHD SPECIAL INSULATED FLUE KIT WITH 900mm S/S REFLECTOR SHIELD

ASH: 8mm THICK FIBRE CEMENT BOARD OR SIMILAR, 0.8 m² K/W PER 4mm THICKNESS

ASH1: 12mm FIBRE CEMENT SHEET (0.8m² K / W PER 4mm SHEET THICKNESS

Ø for minimum constructional requirements see general installation instructions.

Valid only when the fire is exactly at its minimum allowable wall clearance.

NOTE: Where a fan is being fitted, you may prefer to increase the 'A' dimension to 100 mm to provide easier access for servicing. If so, the amount you add to 'A' to bring it to 100 mm must also be added to the 'C' and 'S' dimensions.

FLOOR PROTECTORS (Hearth) REQUIREMENTS CORNER INSTALLATION

MINIMUM FLOOR PROTECTOR DIMENSIONS IN mm

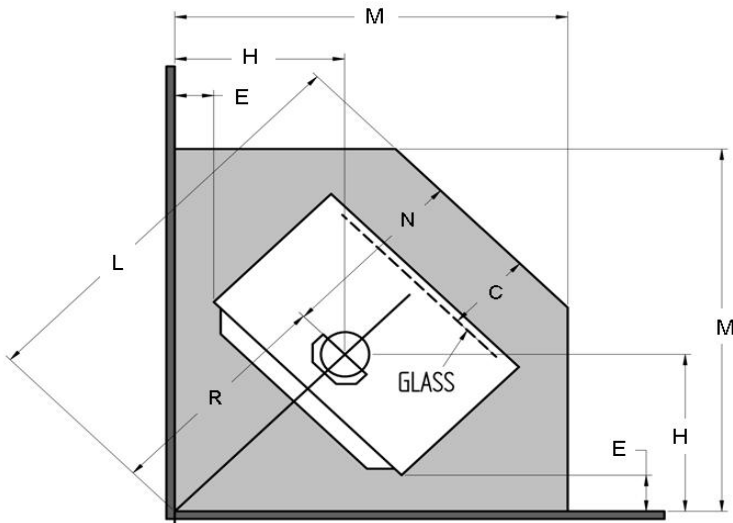

DIMENSIONS IN THE TABLE ARE VALID ONLY WHEN THE FIRE IS EXACTLEY AT ITS MINIMUM ALLOWABLE WALL CLEARANCE.

NEW ZEALAND

MODEL	Flue Shield	Floor Protector Distance above Floor	C	E	H#	L#	M#	N	R#	FLOOR PROTECTOR TYPE
NOT AVAILABLE										

AUSTRALIA

MODEL	Flue Shield	Floor Protector Distance above Floor	C	E	H#	L#	M#	N	R#	FLOOR PROTECTOR TYPE
WESTCOTT 2000	HFS		300	150	426	1072	913	470	602	ASH
	AGA		300	50	326	931	813	470	461	ASH1

HSF: HAWKWIND STD FLUE KIT

AGA: AIR GROUP / AHD SPECIAL INSULATED FLUE KIT WITH 900mm S/S REFLECTOR SHIELD

ASH: 8mm THICK FIBRE CEMENT BOARD OR SIMILAR, 0.8 m² K/W PER 4mm THICKNESS

ASH1: 12mm FIBRE CEMENT SHEET (0.8m² K / W PER 4mm SHEET THICKNESS

FREE STANDING FIRE DIMENSIONS

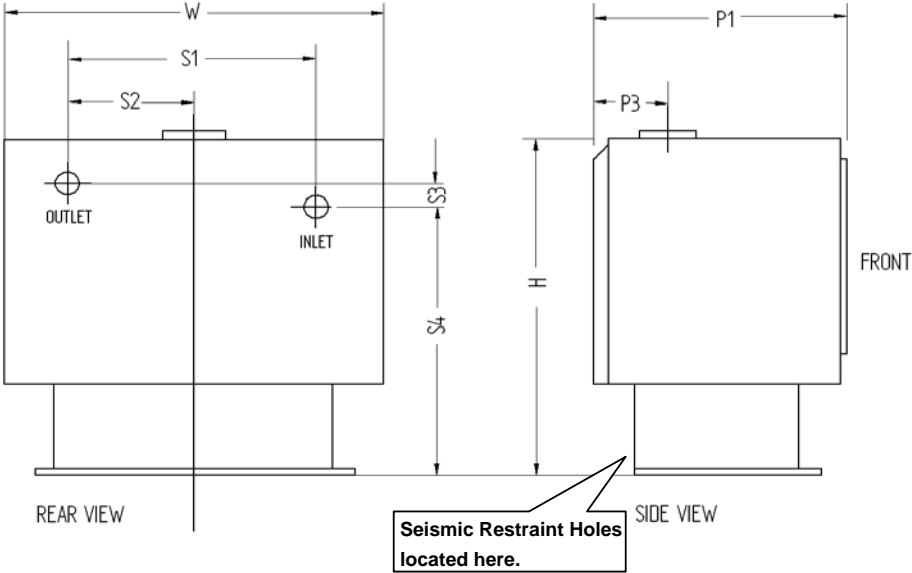

MODEL		P1	P3	H	W	S1	S2	S3	S4
WESTCOTT 2000		302	120	550	540	N/A	N/A	N/A	N/A

Seismic Restraint - In New Zealand and parts of Australia, it is required that the wood fire and floor protector are secured to prevent shifting in the event of an earthquake. This is best done by fastening the wood fire right through the protector to the floor, using two screws not less than 12 gauge or the equivalent size of coach bolts or toggle fasteners